

C-Band 3-Beam 2x2 Antenna [3300-4000 MHz]

GP1606-07969

Description:

- 2x2 MIMO 3-beam antenna for high-capacity stadium/venue or special events applications
- 3-beams (6-ports) 3300-4000 MHz; each beam with 2x2 MIMO capability
- 6° Fixed Electrical Downtilt
- Patent pending technology allows for stable azimuth beam directions over the entire operating frequency band
- Excellent alternative to large lens-based multibeam antennas



2x2 MIMO 3300-4000 MHz 3-Beam Antenna

Electrical Specifications

Frequency Band [MHz]	3300-3550	3550-3700	3700-4000
Gain, max. (dBi)	18.2	18.7	19.0
Gain, avg. (dBi)	17.2	17.6	17.5
Azimuth Beamwidth (°)	24	23	21
Azimuth Beam Spacing (°)	33		
Azimuth Beam Crossover (dB)	8	9	10
Elevation Beamwidth (°)	13.9	13.3	12.6
Electrical Downtilt (°)	6 FET (per each 2x2 beam cluster)		
First Upper Sidelobe Suppression (dB)	18.2	20.5	17.4
Front-to-Back Ratio, 180° (dB)	34	35	34
Cross-Pol Discrimination @ Boresight (dB)	25	25	23
VSWR / RL (dB)	1.50:1 / 14.0		
Port-to-Port Isolation, Intrabeam (dB)*	25		
Port-to-Port Isolation, Interbeam (dB)**	14.0		
PIM @ 2x43 dBm, (dBc)	-145		
Max Power per Port (W)	100		
Polarization (°)	Dual slant 45 (±45)		
Impedance (Ω)	50		

* Port-port isolation between each cluster of four ports in the same 2x2 MIMO beam

** Port-port isolation between any combination of ports between different beams

RFD#: 7969 ; Revision: R1 ; Release Date: August 12, 2024;

Electrical Specifications - BASTA

Frequency Band [MHz]	3300-3550	3550-3700	3700-4000
Gain Over All Tilts, avg. (dBi)	17.2	17.6	17.5
Gain Over All Tilts Tolerance (dB)	0.9	0.8	1.1
AZ Beamwidth Tolerance (°)	4.3	3.7	3.5
EL Beamwidth Tolerance (°)	0.6	0.6	1.0
Upper Sidelobe Suppression, Peak to +20° (dB)	14.2	16.9	14.3
Front-to-Back Ratio, Total Power, +/-30° (dB)	22.1	23.1	20.6
Cross-Polar Discrimination at Boresight (dB)	20.7	21.7	19.5
Azimuth Beam Peak Tolerance (°)	1.1	0.7	1.1
Azimuth Beam Crossover Tolerance (dB)	1.2	0.9	1.3

Bottom Plate & Port Designation Details

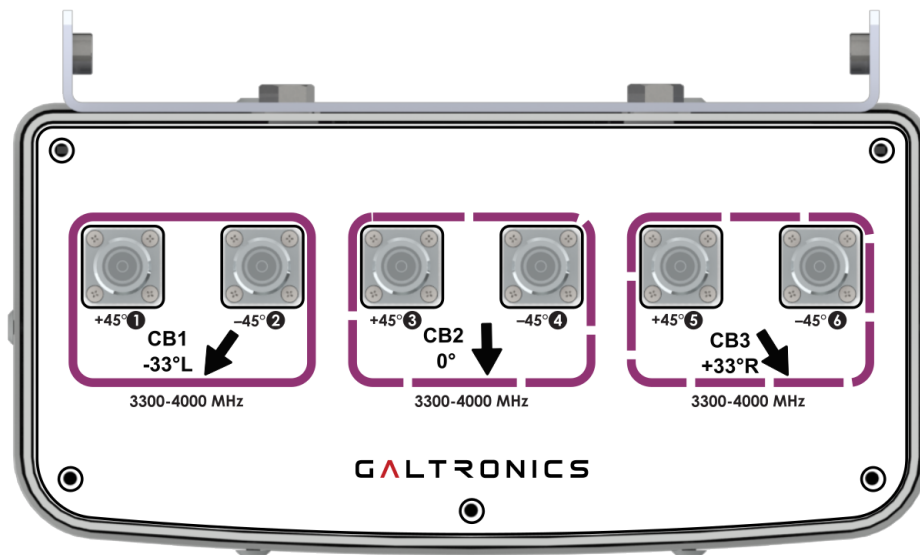

Port/Beam Designator Table

Frequency Range	Ports	Beam Assignment	AZ Beam Direction	Downtilt
3300-4000 MHz	1 - 2	CB1	-33° L	6° Fixed
3300-4000 MHz	3 - 4	CB2	0°	6° Fixed
3300-4000 MHz	5 - 6	CB3	+33° R	6° Fixed

2D Antenna Patterns

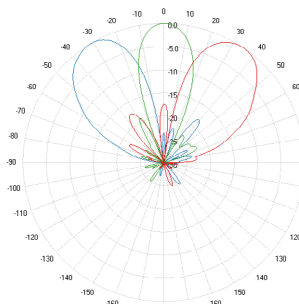

3450 MHz

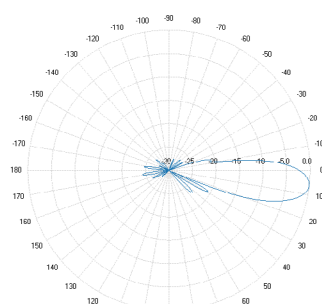

3650 MHz

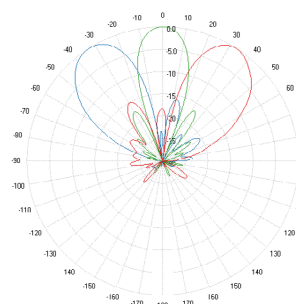

3780 MHz

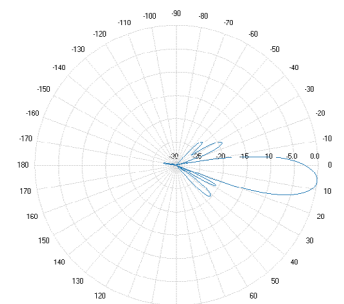

3940 MHz

Antenna Outline

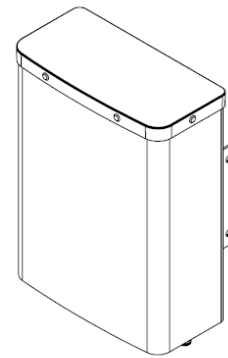
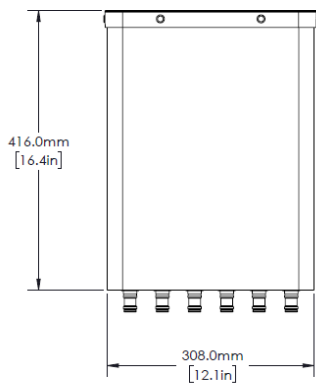
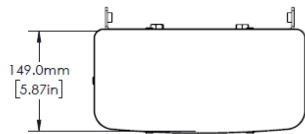

Mating Connector Torque:
4.3-10: 3.7 ft-lb (5 Nm)

RFD#: 7969 ; Revision: R1 ; Release Date: August 12, 2024;

Mechanical Specifications

Operating Temperature	-40° to 158°F (-40° to +70°C)
Antenna Weight	15.0 lbs (6.8 kg)
Antenna Dimension (Height x Width x Depth)	16.4" (416 mm) x 12.1" (308 mm) x 5.9" (149 mm)
Input Connector Type	6x 4.3/10 (F)
Radome Material	ASA
Radome Color	Gray
Environment Rating	Outdoor
Wind Survival Rating	150 mph (241 km/h)

Part Numbers & Ordering Options

Description	Color	Mounting Kit	Part Number
2x2 MIMO 3300-4000 MHz 3-Beam Antenna, 6° FET with 6x 4.3-10 (F) Connectors	Gray	Includes MK-06853 Wall/Pole Mounting Bracket	GP1606-07969-112

Mounting Kit and Accessories Part Numbers

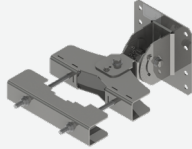
Description:	Part Number:
<p>Heavy Duty Mounting Bracket (150 mph) [INCLUDED]</p> <p>This steel mounting bracket is suitable for outdoor small cell antennas, and can be assembled onto wall and poles ranging from 1.5" to 4".</p>	 <p>MK-06853 (Included)</p>
<p>Heavy Duty Dual Axis Adjustable Mounting Bracket (150 mph) [OPTIONAL]</p> <p>This optional mounting bracket offers an easy installation solution to mount the antenna to either a horizontal or a vertical pole.</p>	 <p>62-45-09 (Sold Separately)</p>

RFD#: 7969 ; Revision: R1 ; Release Date: August 12, 2024;